

# *SELF-PROPELLED APPLICATION EQUIPMENT*



JOHN DEERE



SELF-PROPELLED APPLICATION EQUIPMENT

SOLUTIONS  
THAT  
APPLY





**An expansive sprayer selection. High-capacity nutrient applicators. Hagie’s full lineup of application equipment.** It’s all here. Everything you need to apply. One of the industry’s most comprehensive equipment lines. The latest Precision Ag technology, all fully integrated. Smart time- and money-saving solutions. Secure, open, insightful data management. And the parts, service and support you expect only from your John Deere dealer.

**CATEGORY**

Cab ..... 4-5  
 Boom & ExactApply ..... 6-7  
 Suspension & wheels ..... 8-9  
 Solution systems ..... 10-11  
 PowerTech PSS engines ..... 12-13  
 Spinner spreaders ..... 14-15  
 Self-propelled application equipment ..... 16-17  
 F4365 High-capacity Nutrient Applicator .... 18-19  
 Hagie High-clearance Sprayers ..... 20-21  
 Integrated technologies ..... 22-23  
 Remote support ..... 24-25  
 Attachments ..... 26-27  
 Specifications ..... 28-29

Size up the right John Deere sprayer for you.

Model	Engine hp	Solution capacity	Boom width
R4023	173 (129 kW)	600 gallons (2300L)	Up to 90 feet (27.4 m)
R4030	280 (209 kW)	800 gallons (3000L)	Up to 132 feet (40.2 m)
R4038	310 (231 kW)	1,000 gallons (3800L)	Up to 132 feet (40.2 m)
R4045	346 (258 kW)	1,200 gallons (4500L)	Up to 132 feet (40.2 m)

## A CAB CUSTOMIZED TO FIT THE WAY YOU WORK. SOUNDS GOOD IN THEORY.

We all know how that goes – something might sound good in theory, but when it's applied to real world applications, it doesn't work so well. Fortunately, that's not the case with the new CommandView III cab for John Deere 4 Series Sprayers. Engineered to deliver ultimate comfort and total control, this cab is even better in person.

Increase your visibility, increase your productivity. With 15 degrees of right seat swivel, you'll not only be able to see more, you'll be able to do more. Two internal rearview mirrors and LED lights are offered in the premium cab.





Experience the convenience of total control. The CommandView III cab boasts a fully integrated 4600 CommandCenter display, redesigned CommandARM™ and multi-function handle offering reconfigurable buttons, putting controls right at your fingertips.



**Benefit from fully integrated technologies.** You'll find the latest technology, like the John Deere Connect Mobile app. By providing real-time data, this app enables you to monitor, adjust and learn from your sprayer while it's moving through the field. View mapping of critical job quality information, including as-applied rates, rate deviation, spray pressure and ground speed, and receive high-def documentation for the ExactApply™ nozzle control system for real-time visibility to estimated droplet size. All of this within easy push-button reach, all working together to deliver the most performance and ease of use. Find more details on pages 24-27.

**Easy-to-use touchscreen display.** This high-resolution touchscreen display offers easy-on-the-eyes clarity and simple-to-navigate menus with easy navigation between sprayer settings and on-screen help functions.

## THEORY DOESN'T PROTECT YOUR CROPS

### Introducing Carbon Fiber Booms.

There's a lot on the line when it comes time to spray. Tighter application windows means you've got to move fast and efficiently. The need for multiple passes means a higher risk of damaging crop and soil. It's time to reduce your stress and yield impact. Our big boom theory – harness the incredible properties of carbon fiber and engineer a lightweight, durable boom that not only helps reduce impact but covers more acres in less time. Our all-new carbon fiber booms weave together durability, productivity and weight reduction while reducing corrosion and protecting from soil compaction and crop damage.

Available in 120- and 132-ft. models, our carbon fiber booms reduce boom wing weight anywhere from 35-39% (132 ft. and 120 ft., respectively), improve productivity by 8% (with 132-ft. model) and improve front-to-rear machine weight balance by 6%.



**Built to last.** With a higher strength-to-weight ratio than steel and aluminum, carbon fiber is also corrosion-resistant and easy to clean and maintain.





**Add BoomTrac Pro™ for automatic boom-height control.**

By maintaining correct boom height to target, you'll see improved application accuracy and efficiency, spray coverage and drift management. The boom height adjusts easily from 19 in. (0.5 m) up to 92 in. (2.3 m) to fit your needs.

**Proven design.** We realize carbon fiber isn't ideal for all situations, and that's why we rely on the proven design of our steel booms to get the job done. The rock solid construction includes a reliable dual swing link suspension and greater stability while delivering consistent height above crop, acre after acre. And the flat-fold design lets you spray up to 120 ft. (36 m) wide, covering more acres with fewer passes.

Available for both the inner and outer breakaway sections of the carbon fiber boom, our repair kit enables you to make minor repairs and get back up and running in four to eight hours.

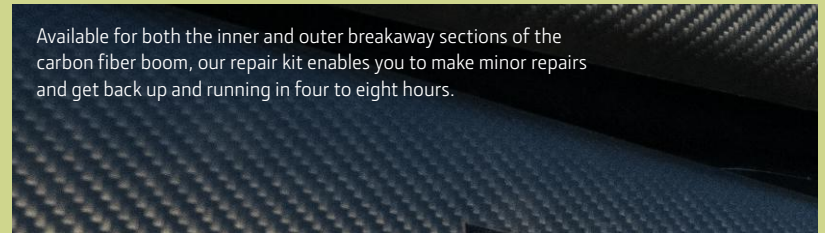

Model	90-ft (27 m) boom 7 sections	100-ft (30 m) boom 9 sections	120-ft (36 m) boom 11 sections	132-ft (40.2 m) boom 13 sections
R4030	•	•	•	•
R4038	•	•	•	•
R4045	•	•	•	•

R4030 | R4038 | R4045 EXACTAPPLY™ NOZZLE CONTROL SYSTEM

## AN APPLICATION EVOLUTION: EXACTAPPLY NOZZLE CONTROL SYSTEM

The next frontier of sprayer technology is here. Experience an unparalleled level of accuracy. Lower your input costs. Decrease the impact on your crop and on the soil. Increase your yield potential. Protect your bottom line.



Combined with Turn Compensation, ExactApply automatically varies the rate across the entire boom, ensuring the application rate for the right area. Not only does this reduce your input cost, but it also saves your plants from harmful crop burn due to over-application and avoids escapes due to under application.



## EVERY DROP COUNTS



And they could easily count against you in the form of over-application, crop burn, and off-target drift. With our ExactApply nozzle control system, application has evolved from simple section control to individual nozzle control for precise application management. Delivering 3X the pulsing frequency of competitive systems and an exclusive A-B nozzle design, ExactApply maintains your target rate and pressure over a wider range of speeds, decreases overlap, reduces input costs and increases your productivity.

**No more test-spraying from the cab.** When checking the spray pattern after changing spray tips or looking for a plugged nozzle, the wireless key fob triggers a test spray from the ground.



## OBJECTS IN MOTION

Experience a smooth, stable ride

From the moment our sprayers are set into motion, you'll feel a big difference in the ride. It's comfortable. It's smooth and steady. It's easy to maneuver. And it's designed to give your overall productivity a boost.

The ride is one of the best in its class. We've included two proven features to cushion you from the bumpiest field conditions – a field-proven dual strut independent wheel air-ride suspension and an auto air-spring leveling system. Both mean less operator adjustment in the field and on the road.

Designed with balance in mind, both the R4030 and R4038 benefit from enhanced overall weight distribution to deliver better balance on the road and in the field. Plus, our optional wheel slip control feature lets you run with confidence in mud and soft soil.

You have plenty of tire options, too, with the versatility you need to handle all your field conditions. At the end of the day, a smooth, stable ride means you'll travel faster across the field, cover more acres and increase productivity. Who doesn't want that?



### Boom stability

Our 4 Series Sprayers feature a swing-link suspension design to reduce vertical boom movement. And when your boom is stable, you get a more consistent spray height, reduced risk of downtime and crop damage, and less fatigue at the end of the day.



### Suspension system

The dual strut independent wheel air-ride suspension cushions you from rough fields to allow faster speeds. The suspension design places two large struts and an air spring at each wheel to isolate operators from rough conditions. Up to 8 in. (20.3 cm) travel space also assures smooth ride.



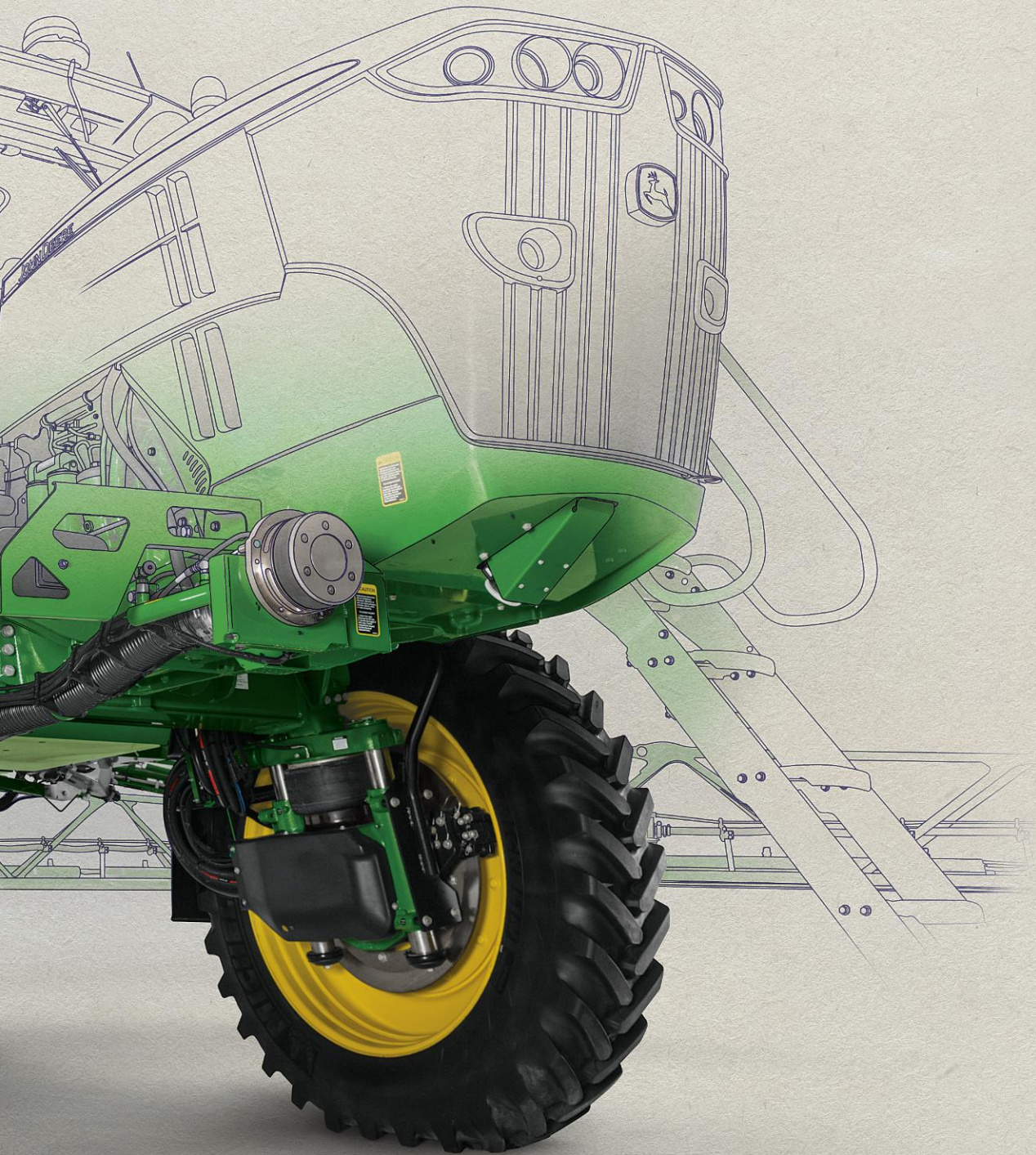

#### Auto air-spring leveling system

Glide through your roughest fields and help keep the chassis level at all times, even as the spray tank empties. The chassis, axle and frame components are made from high-strength structural steel to handle rough field conditions.



#### Tire options

Heavy-duty radial tires deliver excellent traction in virtually any field conditions. Row-crop tires (left) deliver an exceptional ride and reduced compaction due to lower inflation pressures and thicker sidewalls. Flotation tires (right) get you to the field earlier and extend the use season. Also excellent for use in burndown and pre-emergent operations. Both row-crop and wide flotation tires are available on all 4 Series Sprayers. In addition, IF and VF tire options are available for reduced field compaction.

## A PARADIGM SHIFT

Precise, efficient solution systems

Completely redesigned from the ground up with the latest plumbing efficiencies, these sprayers offer higher application rates, extra versatility and faster loading times.

Boost application rates with high-low pump and flowmeter as high as 230 gallons (870L) per minute with the R4045 Sprayer and up to 225 gallons (850L) per minute with the R4038 Sprayer. Even the standard solution pump and single flowmeter option on the R4030 Sprayer delivers higher flow rates than previous models.

Take control of spraying precision, too. With John Deere Section Control, you spray just the areas you want – eliminating overlaps in the field and saving input costs. It's all automatic. Pair this with ExactApply for even more control of your droplets.



**Direct Injection system** increases your flexibility by changing rates and products on the fly without stopping to mix. Increase flexibility by changing rates and products on the fly without stopping to mix products. The integrated system injects products directly into the system at the boom. The results: quicker changeovers, increased flexibility and lowered risk of using multiple products.



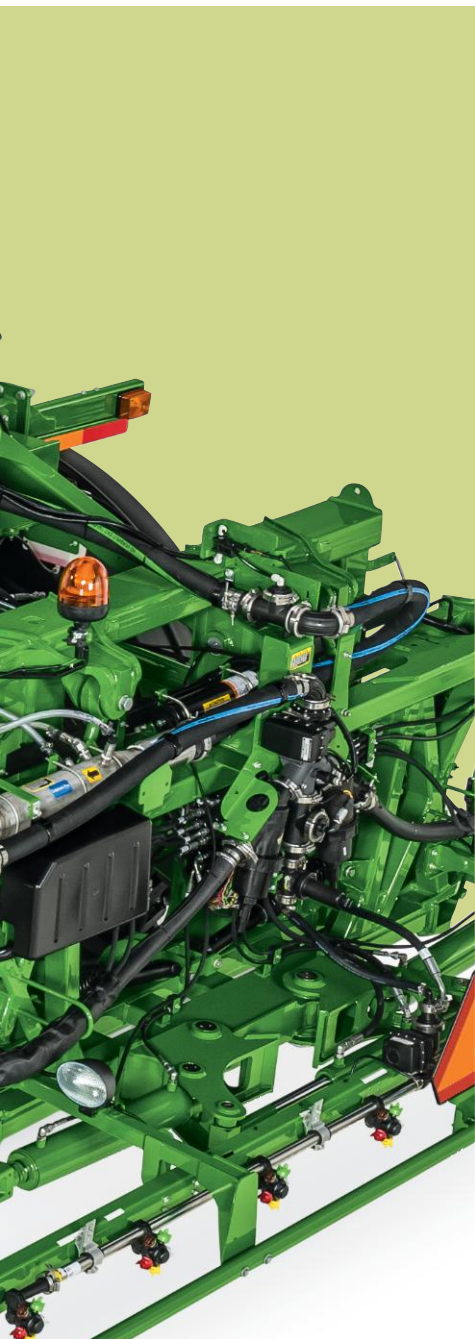

**Exclusive Load Command™ system** dramatically cuts loading time on the R4045 Sprayer only. Load the 1,200-gallon (4,500L) tank as fast as three minutes. System automatically disengages when your sprayer tank is full. Plus, there's reduced risk of any product exposure.

**Front Fill** factory-installed option is available on select 4 Series models to deliver better accessibility and ease of loading to get you back in the field quickly. This feature supports both push-on and pull-on filling, and a simple switch interface lets operators choose which way they would like to fill. Side fill is standard on the 4 Series Sprayers.

**End cap aspirators** on the end of each spray section reduce nozzle turn-off time by up to 85% and terminate dead ends that can collect unwanted product residue. Available in both standard- and high-flow plumbing options – or stainless steel or poly options – this feature rids dead end space and allows air to be expelled.



For the R4030/R4038/R4045 Sprayers, you can speed up load times with the optional **Solution Command System** (shown on far left) for push-button, automated loading that's easy for all operators. The manual loading system (shown on near left) is standard.

#### APPLICATION RATES

Model	High-flow pump, dual flowmeter*	Standard-flow pump, single flowmeter
R4030	N/A	Up to 170 gal. (640L) per min.
R4038	Up to 225 gal. (850L) per min.	Up to 170 gal. (640L) per min.
R4045	Up to 230 gal. (870L) per min.	N/A

\*Optional equipment for R4038 Sprayer. All advertised rates in chart are measured with water.

4 SERIES SPRAYERS POWERTECH™ PSS ENGINES

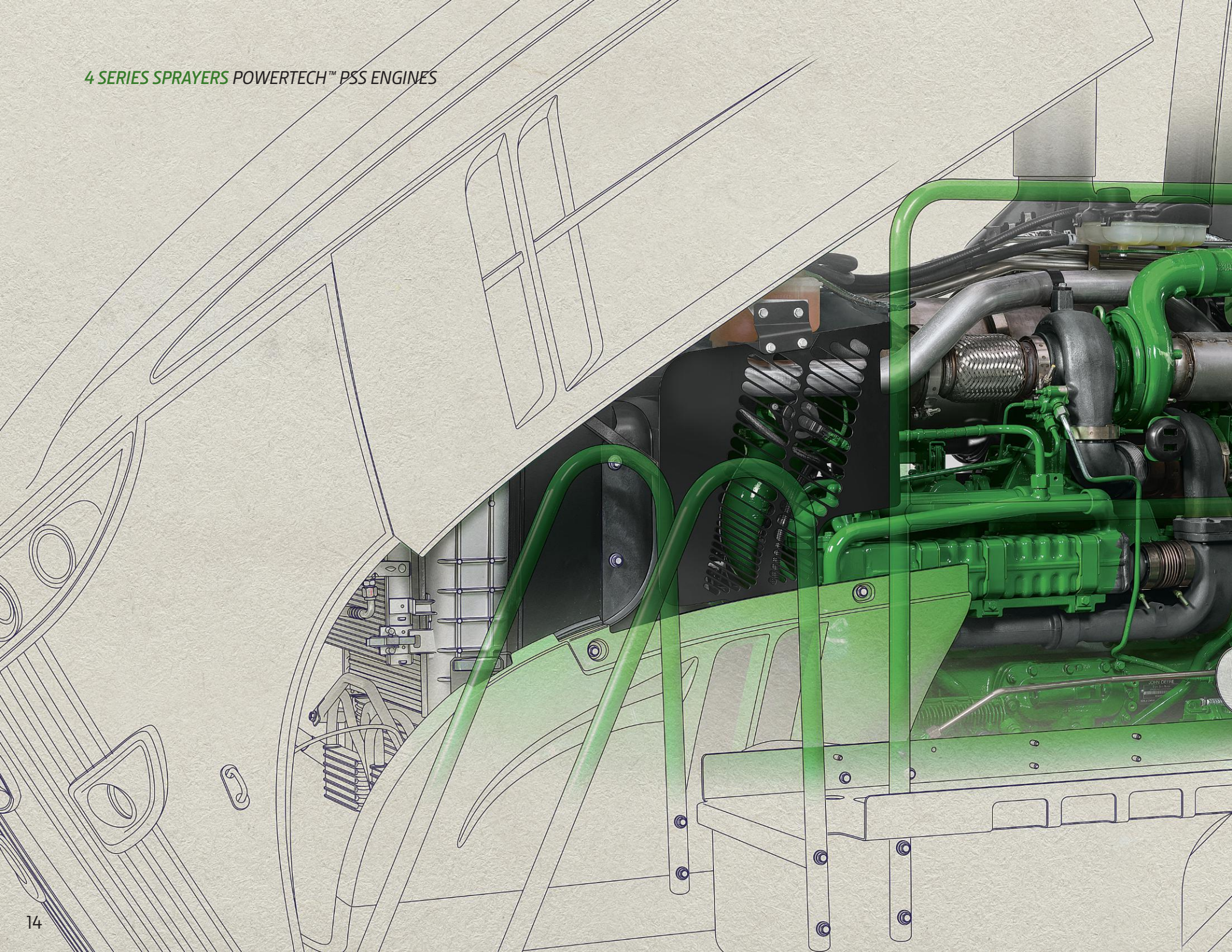

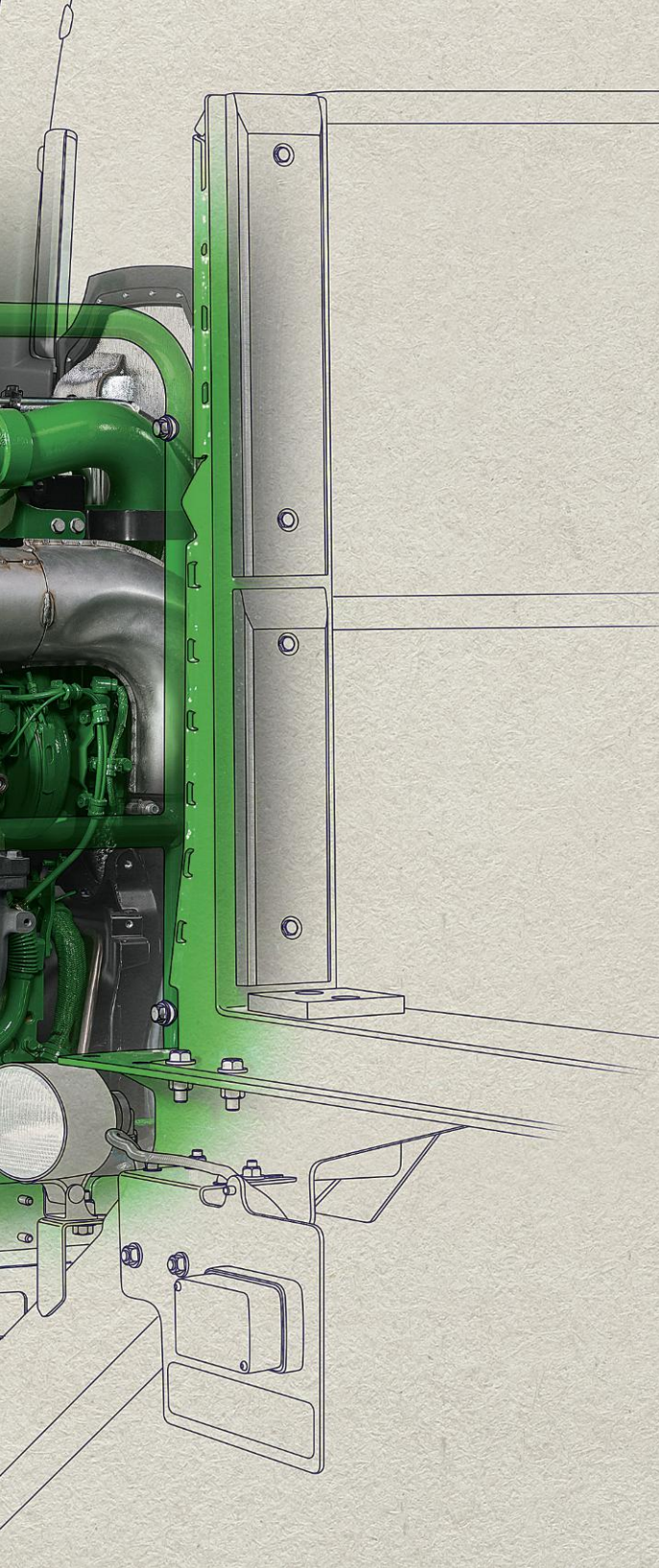

## APPLIED POWER

### PowerTech™ Engines from John Deere

It takes serious horsepower to log serious hours and navigate tough field conditions across thousands of acres. It takes PowerTech™ Engines from John Deere.

All John Deere Self-Propelled Sprayers perform strong and run lean. Each of our four sprayers feature PowerTech PSS engines that meet Final Tier 4 emission requirements. The 9.0L engine is shown at left.

Featuring two turbochargers – a variable geometry turbocharger (VGT) and a fixed geometry turbocharger – this engine delivers the torque rise and engine responsiveness you need to conquer tough field conditions.

Advanced design features such as a 24-valve cylinder head (four valves per cylinder) give our 4 Series Sprayers plenty of efficient engine power. With all our sprayers, including the R4023, you can choose from engine horsepower ratings from 173 to 346 hp (129 to 258 kW) to fit your operation

Model	Engine hp	Power bulge hp	Working RPM	Displacement	Fuel tank capacity
R4023	173 (129 kW)	182 (136 kW)	2400 rpm	275 cu. in. (4.5L)	82 gal. (310L)
R4030	280 (209 kW)	300 (224 kW)	2400 rpm	414 cu. in. (6.8L)	130 gal. (492L)
R4038	310 (231 kW)	330 (246 kW)	2250 rpm	549 cu. in. (9.0L)	155 gal. (587L)
R4045	346 (258 kW)	379 (283 kW)	2250 rpm	549 cu. in. (9.0L)	155 gal. (587L)

## R4030 | R4038 | R4045 LAW OF EXPANSION

Run three seasons with dry spinner spreaders

Expand your productivity to three seasons with the ability to swap a liquid system to dry and boost your annual operating returns from each machine. We can complement your fleet to meet peak demand with machines that are ready to perform when the demand is greatest.

Choose from two factory-installed and supported capacities for a perfect fit: the New Leader® DN456 Dry Spinner Spreader (200 cu. ft./5.6 cu. M) or the larger New Leader® DN485 Dry Spinner Spreader (300 cu. ft./8.5 cu. M) available only for the R4045 Sprayer.

The G4 spinner assembly broadcasts crop nutrients faster, wider and more evenly than before in every pass. With a single bin configuration, material can be spread up to 105 ft. (32 m). For customers looking for dual product application, an optional stainless steel second product bin is available on both sizes.\* The dual hopper system features two independent conveyers that can simultaneously apply two products at different rates at widths up to 84 ft. (25.6 m). Single and Multiplier setups allow nutrients to be spread at predetermined rates or variable-rate applications to fit your operation's needs.



\*5 ft. dual bin insert with 66 cu. ft. (1.87 cu. m) capacity on DN456 and 106 cu. ft. (3.00 cu. m) on the DN485.





With the DN485, you can apply at rates as low as 50 lbs./acre (56 kg/hectare) up to 1,100 lbs./acre (1,232 kg/hectare) and still maintain an accurate spread pattern up to 105 ft. (32 m).



Keep spreading in the field longer. Load up to 10 tons (9,072 kg) of product in the DN485 hopper, available on the R4045 Sprayer. With the DN456 hopper, load up to 6.6 tons (6,000 kg) of product.

### Dry Spinner Spreader Specifications

Dry application system	DN456	DN485
Sprayer compatible	R4045/R4038/R4030	R4045
Product spread	Dry fertilizer or lime*	Dry fertilizer
Capacity - no second product bin	200 cubic feet (5.6 cu. m)	300 cu.ft. (8.5 cu. m)
Capacity - with second product bin	106 cubic feet (3.0 cu. m)	162 cubic feet (4.59 cu. m)
Capacity - second product bin	66 cubic feet (1.9 cu. m)	106 cubic feet (3.0 cu. m)
Drybox material	304 or Painted 409 Stainless Steel	304 or Painted 409 Stainless Steel
Spinner disc diameter	24 inches (61.0 cm)	24 inches (61.0 cm)
Fins per disc	4	4
Second product bin	Optional	Optional
Feedgate height	5 inches (12.7 cm) R4045 11 inches (27.9 cm)	5 inches (12.7 cm)
Rate control make	SpreadStar™	SpreadStar™
Body length	132 inches (335.3 cm)	132 inches (335.3 cm)
Body length of second bin insert	60 inches (152.4 cm)	60 inches (152.4 cm)
Estimated weight	3,240 lbs. (1467 kg)	3,740 lbs (1696 kg)
Spread pattern width with single product bin	60-105 ft. (18 m-32 m)	60-105 ft. (18 m-32 m)
Spread pattern width with second product bin	60-84 ft. (18 m-25 m)	60-84 ft. (18 m-25 m)

\*Lime approved on the R4045 only.

## SELF-PROPELLED APPLICATION EQUIPMENT



A high-resolution 10-inch GreenStar™ 4600 CommandCenter™ display and the smartly configured CommandARM™ for fingertip control of important functions.



# DESIGN BY SCIENCE

## Observe the R4023 Sprayer

A 600-gallon (2300L) tank capacity designed with the size you need for your smaller, irregular-shaped fields.

80 ft. (24 m) or 90 ft. (27.4 m) booms you can fold to 60 ft. (18 m) for tighter field conditions. Strong 3D boom design gives the boom exceptional strength to resist fore-aft loads generated by starts, stops and turns, as well as demanding loads caused by folding and unfolding operations.

Smaller, odd-shaped fields require a special type of machine. One that can fit in tight spaces and maneuver tricky turns. One that keeps operators comfortable while maintaining power and efficiency. Our R4023 Sprayer delivers.

**Trailer-ready** adds to this sprayer's flexibility. The compact size lets you haul the R4023 on a trailer to get from field to field. It also easily stores in smaller buildings.

**Unmatched precision integration** eliminates the need for multiple displays. The R4023 Sprayer comes standard with a crisp, clear, high-resolution 4600 CommandCenter™ Display.

**John Deere integrated technologies** help you with the challenges of balancing the right sprayer adjustments all day for peak efficiency. The sprayer-specific CommandARM™ provides fingertip control of important functions and comes coupled with JDLink™\*\* Connect capability and high-tech sprayer features like SprayStar,™ John Deere Section Control, BoomTrac™ Pro and Boom Return to Height. And the new multi-function handle has six reconfigurable buttons, a scroll wheel to select speed range and provides better management of your headlands with the Headland Management System (HMS™) function.

**Ride in comfort** with the all-leather, heated, ventilated seat featuring nine vertical and lateral adjustments, back support and a larger seat cushion than before.

**Soft Shock option** is ideal for spraying in rougher terrain such as no-till or strip-tilled fields. It's built to absorb the forces these rough terrains can generate, ensuring a smooth ride and accurate spray patterns up to 20 mph (32.2 km/hr).

**Auto-leveling package** is standard on the R4023 to maintain the optimum inflation pressure in the air springs to deliver maximum control in varying field conditions.

**Reduced field compaction** with an IF tire option for the 380 and 320 tires to deliver a bigger footprint and less compaction in varying field conditions.

**Two axle options – wide or narrow** – let you choose the tread spacing that's right for your operation. These minimize compaction and provide flexibility to match the row crop spacings to your specific crop.

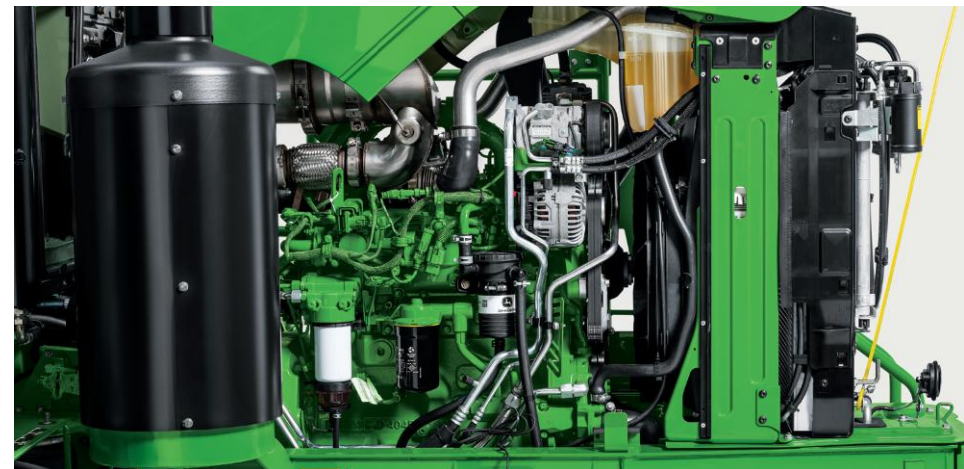

**Final Tier 4 engine** is rated at 173 hp (129 kW) and boosts power 5 percent more than our former model. This 4.5L engine is designed to increase power bulge from 173 to 182 hp (136 kW) with a 10% gain in peak torque. That's dependable power in harsh conditions to let you spray at higher speeds than before.

F4365 HIGH CAPACITY NUTRIENT APPLICATOR

## THE SCIENCE OF SPREADING





F4365	
<b>ENGINE</b>	
Make	John Deere PowerTech™ PSS 9.0L
Peak rated power	365 hp (272 kW) – 9.0 L FT4
Power bulge	400 hp (298 kW)
Fuel tank capacity	150 gal. (567L)
<b>DRY SPINNER SPREADER</b>	
Capacity, cubic feet	330 cu. ft. (9.34 cu. m.)
Configurations	1-4 bins
Spread widths	60-90 ft. (18-27 m.)
Material	304 Stainless or 409 Painted Stainless
Precision ag equipment	4600 CommandCenter™ Display
Rate control	SpreadStar™
<b>DRIVETRAIN</b>	
Transmission	Infinitely Variable Transmission (IVT™)
Drive	2 wheel drive
Application speed	30 mph (48 kph)
Transport speed	46 mph (74 kph)
<b>CHASSIS</b>	
Suspension	Leaf spring with front dampers
Brakes	Air brakes
Turning radius	39 ft. (10.5 m.)
Base tires	Alliance 750/50R26 front tires and 1050/50R32 rear tires
Optional tires	Michelin 750/50R26 front tires and 1050/50R32 rear tires
Ladder raise/lower	Hydraulic
Total empty weight with single bin	31,000 lb. (14,061 kg)
<b>OPTIONS</b>	
Operator station	CommandView III Cab (standard or premium)
Lighting	Halogen or LED



## MEET THE F4365 HIGH-CAPACITY NUTRIENT APPLICATOR



The 4600 CommandCenter Display features easy and intuitive harvest run screens. Shortcut buttons make it easy to navigate, and you can easily swipe through a series of user-defined run pages.

**Improved ride quality.** According to test results, ride quality in the F4365 is **30% better than the leading competitive 4-wheel machine.** With so much extra comfort and ease of use, you'll see a boost in productivity.

**Big capacity.** The higher-capacity 330 cu-ft (9.3 cu m) dry spinner spreader is capable of 60- to 90-ft (18.3 m to 27.4 m) spread widths. That's perfect for delivering higher volumes of N, P, K and lime to replenish the soil. As application windows in early spring and late fall keep getting tighter, the F4365 helps you cover more acres in less time.

**Command in comfort.** With industry-best visibility and roominess, the quiet CommandView™ III cab keeps you comfortable during those long days.

**Easy and efficient.** Take a seat by the smartly configured CommandARM™ for fingertip control. Capture, manage and transfer data more efficiently with the 4600 CommandCenter™ display. And through our updated SpreadStar™ application, you can manage application rates of dry fertilizer, lime and micronutrients for up to four bins. All-important information is displayed on one screen, including AutoTrac™ guidance, dry spinner spreader details, and variable-rate and coverage maps.

HAGIE HIGH CLEARANCE SPRAYERS

# THE NEXT FRONTIER OF SPRAYING SOLUTIONS

John Deere + Hagie Manufacturing





## Two Elements that Create a Great Force

We know application isn't a one-time event. Depending on a number of factors, you could spray multiple times throughout the growing cycle. So naturally it makes sense to offer our customers products that can meet their needs throughout the season. Enter Hagie Manufacturing.

Having developed the first self-propelled sprayer, front-mounted boom and high-clearance nitrogen toolbar, Hagie is a proven pioneer of the application industry. Founded in 1947, Hagie specializes in providing the market with new solutions for evolving farming needs. Their products provide full season capabilities, so you're able to keep products flowing all season long. For example, their Nitrogen

Toolbar (NTB) enables you to make application decisions later in the season based on growing conditions. Not only does this help in rescue situations, but it also helps increase nitrogen efficiency since rate decisions can be made at any point. This ensures that nutrients are applied when the plant needs them the most.

This joint venture delivers the same world-class dealer support, service and warranty you've come to expect from your John Deere dealer and applies them to a broader portfolio of products, ensuring your needs are met every step of the way.



One of the greatest benefits to emerge from this joint venture is the addition of John Deere Precision Ag technology on Hagie equipment. Our AutoTrac™/GreenStar™ field conversion kits give you access to this innovative technology. Use them in conjunction with a StarFire™ 6000 receiver, John Deere Rate Controller 2000, and GreenStar 3 2630 Display and enable documentation, guidance, and rate and section control. And these capabilities are available factory installed starting with Model Year 2018 machines.

MODEL	Engine HP	Liquid Capacity	Boom Width
Dual Tank Series			
DTS10	225	1000 gal	Up to 90 ft
Single Tank Series†			
STS10	300	1000 gal	Up to 132 ft
STS12	300	1200 gal	Up to 132 ft
STS14	300*	1400 gal	Up to 132 ft
STS16	375*	1600 gal	Up to 132 ft

†Compatible with NTB Nitrogen Toolbar, HsTB High Speed Toolbar, DTB Detassling Toolbar

\*John Deere 9.0L PowerTech





## OUR NETWORK OF INTEGRATED TECHNOLOGIES

You're looking at the latest advances in technology – all fully integrated to deliver the most performance and cover more acres in your day. Everything you see here has been designed for peak efficiency and precision.

AutoTrac™ sprayer guidance systems help protect you from what we like to call Row Rage. What's Row Rage you ask? It happens to the best of operators who steer by hand. That feeling of fatigue and frustration when you run over crops. That feeling of stress so severe it can reach the break point – that's Row Rage.

Our answer to Row Rage is two-part: **AutoTrac Vision** and **AutoTrac RowSense**. Both of these hands-free guidance systems help operators of all experience levels keep their 4 Series Sprayer on track without taking out crops or wearing out operators.

**AutoTrac Vision** uses a front-mounted camera to see early-season corn, soybeans and cotton at least 6 inches (15cm) high. An industry exclusive from John Deere.

**AutoTrac RowSense** uses a paddle sensor mounted on the sprayer's front wheels to feel mature cornstalks in late-season rows. Currently approved for 30-inch corn rows only.

With both systems, operators can spray faster with less fatigue – especially valuable in tight application windows. Increasing sprayer speed from 14 to 18 mpg (22.5 to 29 km/h) can allow an operator to cover 20% more acres every day. Plus, both systems dramatically reduce yield-robbing crop damage.



Mac and OS X are trademarks of Apple Inc., registered in the U.S. and other countries.

AgLogic™ automated work order system helps you manage and improve the productivity of your entire fleet, even non-John Deere machines, from any computer with Internet access. Put everyone on the same page with less paperwork, fewer phone calls and less hassle. Available on a bigger-screen Android tablet and Apple iOS. Not available in Canada.



John Deere Mobile Weather provides instant, field-specific, on-the-go weather information to help you make the most of your application effectiveness.

The tablet screen displays a 'Remote Display Access' interface for a John Deere machine. The interface includes the following data:

- Header:** Remote Display Access (1RW8335RPDP072269)
- Machine Info:** 3D SF1, SN 309126, Serial Port
- Positioning Data:**
  - Position Mode: 3D SF1
  - Accuracy (%): 100
  - Lat (°): 41.2573482°
  - Lon (°): -94.7745547°
  - Altitude (ft): 1251.094
  - GPS Signal (%): 100
  - GPS Course (°): 174
  - SF Signal (db): 9.6
  - GPS Speed (mph): 0.0
- Orientation Data:**
  - Roll Angle (°): 2.4
  - Pitch Angle (°): 0.7
  - Yaw Rate (°/sec): 0
- Additional Info:** 450pm



## THE NUCLEUS OF YOUR OPERATION

John Deere Operations Center is the hub of your data collection and management.

It's never been easier to collect cost-saving data and seamlessly deliver it to you. With John Deere Operations Center, you'll gain access to prescription information and more, and have the ability to share it with trusted advisors to receive additional insights. And with additional remote support tools like JDLink Connect,<sup>™\*</sup> Remote Display Access, Service ADVISOR<sup>™</sup> Remote and our mobile apps, you'll minimize downtime and maximize data collection.

**Remote Display Access** lets you check your machine diagnostics, allowing owners, managers and even dealers (with your permission) the ability to view your display remotely and save a trip to the field.

**Service ADVISOR<sup>™</sup> Remote** with JDLink helps reduce downtime with your John Deere dealer's help. Your dealer can warn you of any potential problems with your machine and start working on a solution right away, saving on the technician's travel time and expense, and helping reduce your downtime.

**Mobile apps** provide data-driven insights at your fingertips anytime and anywhere. The **MyOperations<sup>™</sup> App** connects you to in-cab displays and provides field productivity information, weather and fuel level data. Or try our **MyAnalyzer<sup>™</sup> App** for access to documented map layers and farm summaries in the field and on the go. And the new **Connect Mobile App** lets you make real-time decisions that make a difference while you're spraying. This iPad app delivers a nozzle-by-nozzle level of detail, in addition to as-applied rate, rate deviation and ground speed.

**JDLink Connect** lets you stay informed with machine logistics, receive real-time alerts and keep preventative-maintenance tabs on your machines, all from your office or mobile device. All new models come with one-year of free subscription to JDLink service. With John Deere



Connected Support, your dealer can receive alerts and connect to your equipment. Most new John Deere machines come ready with 5 years of machine connectivity to enable these tools that you keep running.

### Customize your sprayer, optimize your performance

John Deere performance parts and attachments are more than “nice to have” options. They make good business sense – saving you time, helping you protect your sprayer investment, boosting your efficiency, and making you more comfortable in the cab – so you can stay in the field longer. Check out the optional time- and money-saving parts and attachments for your John Deere sprayer. Then see your dealer for details on these productivity boosters and many more.



**Technozzlegy™**  
*(tek-noz'-uhl-jee)*  
**The next generation of sprayer nozzle performance**  
John Deere is redefining sprayer performance and accuracy with a concept so advanced we're calling it Technozzlegy. Engineered for pinpoint accuracy, each nozzle reaches the exact part of the plant you're aiming at for every application: fertilizer, herbicide, fungicide and insecticide. Ask your John Deere dealer for details. *For all 4 Series Sprayers.*



**QuickLub® (Lincoln Lube) automatic lubrication system**  
Stay in the field longer, and spray with confidence with QuickLub. This kit automatically meters the right amount of grease to the chassis and boom. By purging contaminants, this kit delivers excellent lubrication of wear surfaces and a solid grease seal for extra protection. *For all 4 Series Sprayers.*



**Flotation tires**  
Extend the use season and get in the field earlier. Excellent for use in burn down and pre-emerge operations, and when fields are soft or wet. *For specific sizes, please refer to specifications chart on page 27.*

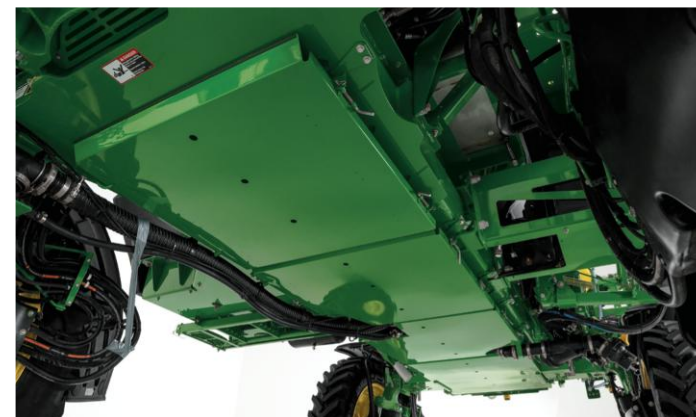

**Underframe shields**  
Simply mount these shields to the underside of the chassis to help protect your crop from entanglement in vehicle components. Shields are mounted on hinges to allow quick, easy access to vehicle components. *For all 4 Series Sprayers.*



#### **Fencerow spray nozzle kit**

Increase your spraying coverage along fencerows with this kit. The XT nozzle helps you cover an additional 16.5 ft (5.03 m). It's as easy as flipping a switch in the cab. Spray nozzles sold separately. *For all 4 Series Sprayers.*



#### **Boom air purge conversion**

During product changeover, the boom air purge conversion forces air through the boom to help clean it out. Activated via the GreenStar™ display. *For R4030, R4038 and R4045 Sprayers.*



#### **Direct Injection**

Now you can accurately inject product into the carrier flow without having to mix products in the solution tank. That means no more rinsing the tank prior to switching products – ever. The results are easier changeover between crops, faster loading times, and fewer wasted products. *For R4030, R4038 and R4045 Sprayers.*

4 SERIES SPRAYERS SPECIFICATIONS



	R4023	R4030	R4038	R4045
<b>ENGINE</b>				
Make	John Deere PowerTech™ Plus 4.5L	John Deere PowerTech™ PSS 6.8L	John Deere PowerTech™ PSS 9.0L	John Deere PowerTech™ PSS 9.0L
Peak rated power	173 hp (129 kW) - 4.5L – Tier 4	280 hp (209 kW) - 6.8 L – Tier 2 or FT4	310 hp (231 kW) - 9.0L – Tier 2 or FT4	346 hp (258 kW) - 9.0 L – Tier 2 or FT4
Power bulge	182 hp (136 kW)	300 hp (224 kW)	330 hp (246 kW)	379 hp (283 kW)
Displacement	275 cu. in. (4.5L)	414 cu. in. (6.8L)	549 cu. in. (9.0L)	549 cu. in. (9.0L)
Fuel tank capacity	82 gal. (310L)	130 gal. (492L)	155 gal. (586L)	155 gal. (586L)
<b>SOLUTION SYSTEM</b>				
Capacity, U.S. gallon (l)	600 gal. (2300L)	800 gal. (3000L)	1,000 gal. (3800L)	1,200 gal. (4500L)
Tank material	Polyethylene	Stainless steel or polyethylene	Stainless steel	Stainless steel
Rinse tank capacity	70 gal. (265L)	120 gal. (454L)	120 gal. (454L)	170 gal. (646L)
Quick Fill™ size	2 in. (5 cm) Side-Mount	3 in. (7.6 cm) Side-Mount; Optional 3-in. Front Fill	3 in. (7.6 cm) Side-Mount; Optional 3-in. Front Fill	3 in. (7.6 cm) Side-Mount; Optional 3-in. Front Fill or Optional LoadCommand
Rate control make	SprayStar™ System	SprayStar™ System	SprayStar™ System	SprayStar™ System
Precision ag equipment	GreenStar™ 4600 CommandCenter™ Display	GreenStar™ 4600 CommandCenter™ Display	GreenStar™ 4600 CommandCenter™ Display	GreenStar™ 4600 CommandCenter™ Display
Suction strainer	16 mesh	20 mesh	20 mesh	20 mesh
Pressure strainer	50 mesh	50 mesh	50 mesh	50 mesh
Boom strainer	80 mesh	80 mesh	80 mesh	80 mesh
<b>BOOM</b>				
Boom width options, Steel	60, 80, 90 (18.2, 24.3, 27.4 m)	90, 100, 120 ft. (27, 30, 36 m)	90, 100, 120 ft. (27, 30, 36 m)	90, 100, 120 ft. (27, 30, 36 m)
Plumbing material, Steel	Polypropylene pipe	Stainless steel (polypropylene optional)	Stainless steel (polypropylene optional)	Stainless steel (polypropylene optional)
Ground ht. adjustment, Steel	15-76 in. (38-193 cm)	19.6- 96.5 in (50-245 cm)*	19.6- 96.5 in (50-245 cm)*	19.6- 96.5 in (50-245 cm)*
Breakaway length, Steel	6 ft. (1.82 m)	Tip-10.8 ft. ( 3.3 m) & Full Boom Breakaway	Tip-10.8 ft. ( 3.3 m) & Full Boom Breakaway	Tip-10.8 ft. ( 3.3 m) & Full Boom Breakaway
Boom sections, Steel	7	7, 9, 11	7, 9, 11	7, 9, 11
Boom width options, Carbon Fiber	N/A	120, 132 ft. (36, 40 m)	120, 132 ft. (36, 40 m)	120, 132 ft. (36, 40 m)
Plumbing material, Carbon Fiber	N/A	Stainless steel	Stainless steel	Stainless steel
Ground ht. adjustment, Carbon Fiber	N/A	19.6- 96.5 in (50-245 cm)*	19.6- 96.5 in (50-245 cm)*	19.6- 96.5 in (50-245 cm)*
Breakaway length, Carbon Fiber	N/A	Tip-12.1 ft. ( 3.7 m) & Full Boom Breakaway	Tip-12.1 ft. ( 3.7 m) & Full Boom Breakaway	Tip-12.1 ft. ( 3.7 m) & Full Boom Breakaway
Boom sections, Carbon Fiber	N/A	11, 13	11, 13	11, 13
<b>DRIVETRAIN</b>				
Type	Hydrostatic	Hydrostatic	Hydrostatic	Hydrostatic
Drive	Full-time 4WD	Full-time 4WD	Full-time 4WD	Full-time 4WD
Shifting	Electrohydraulic	Electrohydraulic	Electrohydraulic	Electrohydraulic
Hydraulic reservoir capacity	16 gal. (60L)	26 gal. (98.4L)	26 gal. (98.4L)	26 gal. (98.4L)
Spray speed	20 mph (32.2 km/h)	20 mph (32 km/h)	25 mph (40 km/h)	25 mph (40 km/h)
Transport speed	27 mph (43.5 km/h)	30 mph (48 km/h)	35 mph (56 km/h)	35 mph (56 km/h)
<b>CHASSIS</b>				
Dry spinner spreader compatible	N/A	DN456 -200 cu. ft (5.7 cu. m)	DN456 -200 cu. ft (5.7 cu. m)	DN456 & DN485 - 200 or 300 cu. ft (5.7 to 8.5 cu m)
Suspension	Air bag/shock suspended axles	Dual strut independent wheel air-ride suspension	Dual strut independent wheel air-ride suspension	Dual strut independent wheel air-ride suspension
Ground clearance with standard tires	50 in. (127 cm)	60 in. (152 cm)	60 in. (152 cm)	58 in. (147 cm)
<b>TIRES</b>				
Factory-installed	IF320/80R42, 380/80R38, IF380/80R38, 420/85R34	320/90R46, IF320/90R46, 380/90R46, IF380/90R46, VF380/90R46, IF420/80R46	IF320/90R46, IF380/90R46, VF380/90R46, IF420/80R46	IF380/105R50, VF420/95R50, 480/80R50
Options	IF320/80R42, 380/80R38, IF380/80R38, 420/85R34	IF320/90R46, 380/90R46, IF380/90R46, VF380/90R46, IF420/80R46, 520/85R38, 620/70R38	IF320/90R46, IF380/R46, VF380/90R46, IF420/80R46, 520/85R38, 620/70R38	IF380/105R50, VF420/95R50, 480/80R50, 620/70R46, IF800/55R46
Tread adjust	90-120 in. (228-305 cm), Wide 72-88 in. (183-224 cm), Narrow	Hydraulic 120-160 in. (305-406 cm) tire size	Hydraulic 120-160 in. (305-406 cm) tire size	Hydraulic 120-160 in. (305-406 cm) tire size
Turning radius	16.0 ft. (4.9 m)	28.5 ft. (8.7 m)	28.5 ft. (8.7 m)	28.5 ft. (8.7 m)
Parking brake	Spring-engaged, hydraulic-disengaged disk pack	Hydrostatic	Hydrostatic	Hydrostatic
Ladder raise/lower	Hydraulic	Hydraulic	Hydraulic	Hydraulic
Total dry wt., 80 ft. boom, Steel	18,370 lbs. (8,332 kg)	N/A	N/A	N/A
Total dry wt., 90 ft. boom, Steel	N/A	29,810 lbs. (13,550 Kg)	30,833 lbs. (14,015 Kg)	35,350 lbs. (16,068 Kg)
Total dry wt., 100 ft. boom, Steel	N/A	29,986 lbs. (13,630 Kg)	30,998 lbs. (14,090 Kg)	35,521 lbs. (16,146 Kg)
Total dry wt., 120 ft. boom, Steel	N/A	30,558 lbs. (13,890 Kg)	31,559 lbs. (14,345 Kg)	36,080 lbs. (16,400 Kg)
Total dry wt., 120 ft. boom, Carbon Fiber	N/A	27,963 lbs. (12,684 Kg)	29,330 lbs. (13,304 Kg)	34,048 lbs. (15,444 Kg)
Total dry wt., 132 ft. boom, Carbon Fiber	N/A	28,084 lbs (12,739 Kg)	29,451 lbs. (13,359 Kg)	34,169 lbs. (15,499 Kg)
<b>OPTIONS</b>				
Air compressor	On Board Air Standard	On Board Air Standard	On Board Air Standard	On Board Air Standard
Foam marker compatibility	Injection Foamer	Injection Foamer	Injection Foamer	Injection Foamer
Chemical eductor	Stainless steel	Stainless steel	Stainless steel	Stainless steel
Operator Station	Standard Cab or Premium Cab	CommandView III Cab	CommandView III Cab	CommandView III Cab
Direct Injection	N/A	Up to 235-gal. (890L) ; 3-product	Up to 235-gal. (890L) ; 3-product	Up to 235-gal. (890L) ; 3-product

# Put It On My Multi-Use Account...

For a flexible way to finance

## SEED

with seasonal terms that allow  
me to buy now and pay later †

With the purchasing power  
to pay for essential

## CROP PROTECTANTS

that safeguard my investment

And convenience that helps me get the

## FERTILIZER

I need for a successful growing season



The **Multi-Use Account** from John Deere Financial is an essential financing solution that provides an additional source of capital, matches my cash flow and helps me get the important things I need to keep my business moving forward — all season long.

Learn more about the full potential of your account at [MyMulti-UseAccount.com](http://MyMulti-UseAccount.com) or [MyMulti-UseAccount.ca](http://MyMulti-UseAccount.ca)

**CROP INPUTS | FARM SUPPLIES | PARTS, SERVICE & ATTACHMENTS**

Multi-Use Accounts are a service of John Deere Financial, f.s.b.  
DSAA69501 Litho in U.S.A. (17-06)

\*Activation/subscription required. Some additional accessories and/or components may be required. JDLink requires a cellular data connection to transfer information from machine to JDLink website. Consult your local John Deere Dealer for coverage availability.



**JOHN DEERE  
FINANCIAL**

**Multi-Use Account**

†Financing on approved John Deere Financial credit only.  
See your Multi-Use Account merchant for complete details.